

S101EK

10.1" Rugged Tablet with Intel® Celeron® N6211



KEY FEATURES

- Intel® Celeron® N6211 @1.20GHz (up to 3.00GHz), Windows Rugged Tablet PC
- 1920 x 1200 WUXGA with PCAP touch rugged tablet
- 2MP Webcam , 8MP AutoFocus Rear Camera
- Sunlight readable with anti-glare solution
- IP65 water and dust proof with MIL-STD-810H rugged housing
- Optional 1D/2D Barcode Reader
- Removable battery with hot-swap function for all day productivity
- Ethernet thru Giga LAN (RJ45)



SPECIFICATIONS

Display	
Resolution	1920x1200
Contrast Ratio	800:1
View Angles	85,85,85,85
Type	Projected Capacitive Multi Touch
Touch Mode	Support Hand / Gloves and Rain Mode
Size	10.1 inches
Panel Brightness	800.0 nits
Bonding	Optical Bonding for Sunlight Viewability
Viewability	Anti-Glare touch treatment
System Specification	
Processor	Intel Celeron N6211 @1.20 GHz (up to 3.00 GHz) Intel Pentium N6415 @1.20 GHz (up to 3.00 GHz) (Optional)
Storage	128GB SSD Additional storage available with micro SDXC card slot 256GB SSD (Optional) 512GB SSD (Optional)
Memory	4GB DDR4 SDRAM 8GB DDR4 SDRAM (Optional) 16GB DDR4 SDRAM (Optional)
Operating System	Windows 10 IoT Enterprise LTSC (64 bit) Windows 11 IoT Enterprise SAC (64 bit) (Optional)
Security	Trusted Platform Module (TPM) 2.0 Kensington Lock
BT	Support
WLAN	Support
GNSS	GPS, GLONASS
WWAN	4G LTE (Optional) 5G (Optional)
Sensors	Light sensor/ G-sensor / Gyro
Camera	
Front Camera	2MP Front Camera
Rear Camera	8MP Rear Camera with auto-focus and LED light
Mechanical	
Dimension	272 x 192 x 25 mm
Weight	1.1 kg
Cooling System	Fanless design
IO Ports	
USB Port	1 x USB 3.0 (Type A), 1 x USB 3.0 (Type-C support Power Delivery 20V In)
SD Card Slot	1 x Micro SDXC slot
SIM Card Slot	1 x Nano SIM card slot
Video	1 x Micro HDMI (Optional)
Audio	1 x Audio combo 3.5mm audio combo jack (Mic in or Line Out) Dual Mic Built-in Microphone Single Speaker
Expansion Port	1 x Expansion Connector for USB2.0 / UART (Optional)

LAN	1 x RJ45-10/100/1000 GigaLAN port	Indicator	2x LED Indicator for Power, Battery
Docking Connector	1 x 19-pin docking connector		
Environment			
Operating Humidity	10% to 90% RH, non-condensing	Operating Temperature	-20°C to 60°C
Storage Temperature	-30°C to 70°C (-22°F to 158°F)	Shock	MIL-STD-810H Method 516.8 Procedure I
Vibration	MIL-STD-810H Method 514.8 Procedure I	IP rating	IP65
Drop	MIL-STD-810H Method 516.8, 4 ft		
Certification			
Certification	CE, FCC		
Security Function			
SOTI MobiControl	SOTI MobiControl Compliance	Kensington Lock	Kensington Lock Support
Control			
Button	1 x Power 2 x Programmable function Keys		
Power			
Battery	11.4V, typ. 3500 mAh Li-Ion Re-chargeable Battery (3S1P) Hot-Swap (Optional)	Battery Operating Time	Standard. Battery: 6 hours
Power Rating	19V DC	Adapter	100-240V, 50-60Hz / 19V DC
Accessory			
Accessory	Adapter and Power Cord Standard Battery	Optional Accessory	Vehicle Charger (Optional) Battery Charger (Optional) Hand Strap (Optional) Shoulder Strap (Optional) Carry Bag (Optional) Stylus (Optional)
Barcode Scanner			
Barcode Scanner	1D/2D barcode reader (Optional)		

DIMENSIONS UNIT:MM

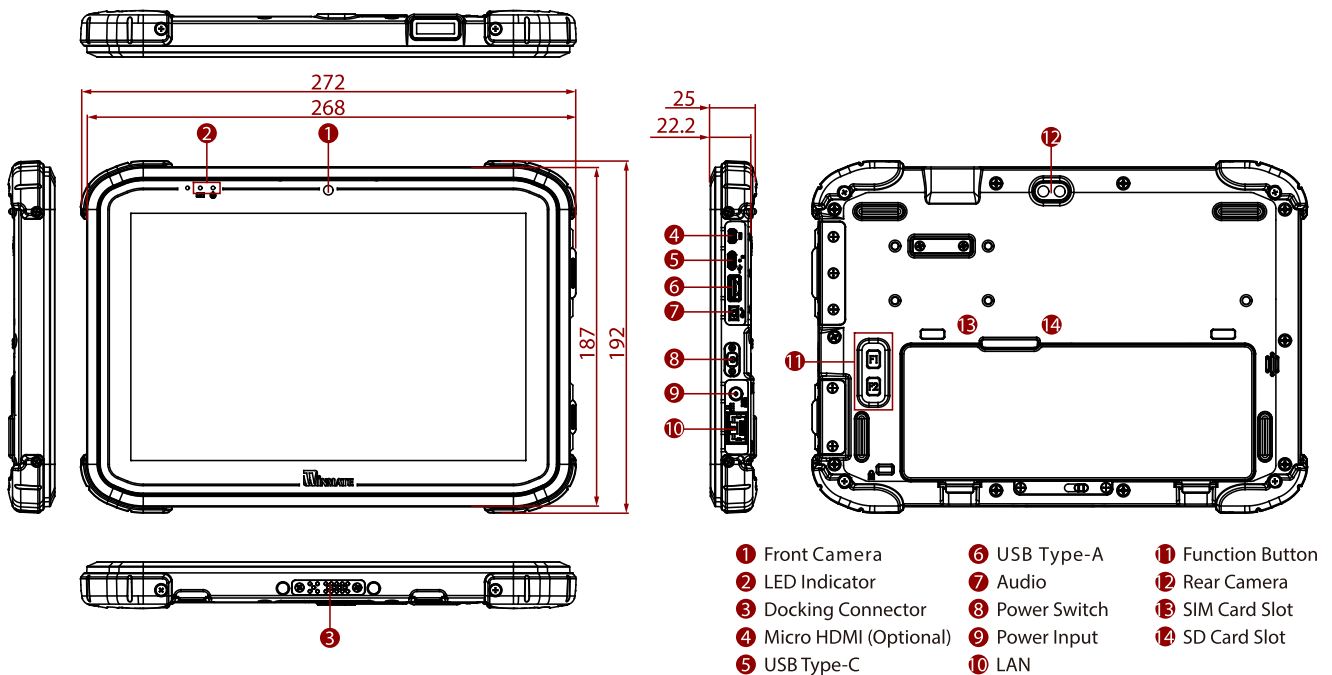

NOTE

1. This is a simplified drawing and some components are not marked in detail.
2. Please contact our sales representative if you need further product information.
3. All specifications are subject to change without prior notice.
4. The product shown in this datasheet is a standard model. For diagrams that contain customized or optional I/O, please contact the Winmate Sales Team for more information.