

R15IE3S-65EX

15" Intel® Atom® x6413E ATEX Panel PC



KEY FEATURES

- Intel Atom® x6413E Processor 1.5M Cache, up to 3.00 GHz
- High Quality 15" Panel, 1024 x 768 resolution, 1000 nits
- P-cap multi touch screen Optical Bonding with Panel to increase the clarity and transparency
- Compliance with ATEX / IECEx / CID2 Design
- Fanless design with streamlined enclosure for highly efficient heat dissipation
- Dust/ Water proof design with VESA mount Full IP65 Panel PC
- Wide Range 9 to 36V DC Input with isolation
- -20 to 60°C wide operating temperature

INTRODUCTION

Winmate ATEX Panel PC Series is designed for safe and reliable performance in hazardous environments, certified for Class 1, Division 2, ATEX Zone 2, and IECEx Zone 2 applications. Powered by Intel® processors, these fanless Panel PCs feature durable, streamlined enclosures for efficient heat dissipation and wide operating temperatures, with optional intelligent heaters for extreme cold down to -40°C. Ideal for industrial and chemical settings, they include high-brightness displays, multi-touch capabilities, IP65-rated protection, and flexible mounting options, ensuring superior usability and safety in challenging conditions.

OVERVIEW



Endorsed for Perilous Environments

Winmate R15IE3S-65EX ATEX Panel PC provide a reliable and safe computing solution for industries operating in hazardous environments, helping to improve operational efficiency while ensuring compliance with regulatory standards.

Potent Processing Power and Fanless Cooling

The Winmate R15IE3S-65EX ATEX Panel PC explosion-proof panel pc is driven by an Intel® CPU, boasting a fanless thermal design and sleek enclosure. This combination not only provides effective heat dissipation and top-tier performance for challenging tasks but also ensuring low power consumption and cost-effectiveness.





Completely Durable and Water-resistant(IP65)

The R15IE3S-65EX ATEX Panel PC provides comprehensive IP65 protection against dust and water, making it suitable for use in potentially explosive and challenging environments. Equipped with EX-type brass cable glands featuring M12 ports, it ensures utmost protection in wet and dusty operating conditions.

Versatile Across Temperature Ranges

The R15IE3S-65EX ATEX Panel PC is engineered to function effectively across a wide temperature spectrum, spanning from -20°C to 60°C. This versatility enables its deployment in outdoor settings or hazardous environments, ensuring reliable operation even in extreme hot or cold climates.



Supreme Touch Interaction

Improve customer interaction with PCAP touch technology, enabling multi-touch control with effortless finger manipulation. Delight in seamless touch functionality and ease of use with the R15IE3S-65EX, offering unparalleled durability for demanding applications like controlling a drilling rig's panel.

SPECIFICATIONS

System Specification

Processor	Intel Atom® x6413E (up to 3.0GHz)	Memory	1 x SO-DIMM, DDR4 3200 MHz, 4GB 8GB (Optional) 16GB (Optional)
Storage	1 x M.2 2242 B-key SSD 128GB 256GB (Optional) 512GB (Optional)	Ethernet controller	1 x Intel® Ethernet Controller
Operating System	Windows 11 IoT Enterprise (64 bit) (Optional) Windows 11 Pro 64 bit (Optional) Windows 10 IoT Enterprise (64 bit) (Optional) Linux Ubuntu 22.04 (Optional)		

Display

Touch / Glass	Projected Capacitive Multi Touch Screen Bonding With Panel	Resolution	1024x768
Size	15.0 inches	Contrast Ratio	2000:1
Panel Brightness	550 nits 1000 nits(Optional)	View Angles	88,88,88,88
Active Area	304.1x228.1 mm		

Mechanical

Dimension	396 x 310 x 49 mm (Without Box Cover) 396 x 346.4 x 101.7 mm (With Box Cover)	Weight	5.7 kg (Without Box Cover) 10.2 Kg (With Box Cover)
Mounting	VESA Mount	Enclosure	Stainless Housing
Cooling System	Fanless design		

Environment

Operating Humidity	10% to 95% RH, Non-Condensing	Operating Temperature	-20°C to 60°C
Storage Temperature	-30°C to 70°C	Shock	MIL-STD-810G Method 516.6 Procedure I (Optional)
Vibration	MIL-STD-810G Method 514.6 Procedure I	IP rating	IP65
Drop	MIL-STD-810G Method 516.6 Procedure IV		

Certification

Certification	CE, FCC, IC Compliance with ATEX / IECEx / CID2 Design
----------------------	---

IO Ports

Power Input	1 x 9~36V DC, M12 Type connector	USB Port	1 x M12 type connector for 2 x USB2.0
Serial Port	1 x M12 connector for RS232/422/485 (Default RS232)	Expansion Port	1 x M.2 2242 B-key Slot (for SATA III SSD) 1 x M.2 2230 E-Key Slot (for Wi-Fi module)
LAN	1 x M12 type connector for Giga LAN	Indicator	1 x LED Indicator for power 1 x LED Indicator for storage

Control

Button	1 x Power Button 1 x Reset Button
---------------	--------------------------------------

Accessory

Accessory	100~240V AC to DC Power Adapter with M12 Connector Power Cord M12 Type Power Cable
------------------	--

M12 Type RS232 Male Cable
M12 Type USB Female Cable
M12 Type LAN Cable
RJ45 female-female converter
USB Adapter (USB type A to type B)
VESAs screws

DIMENSIONS UNIT:MM

NOTE

- 1.This is a simplified drawing and some components are not marked in detail.
- 2.Please contact our sales representative if you need further product information.
- 3.All specifications are subject to change without prior notice.
- 4.The product shown in this datasheet is a standard model.For diagrams that contain customized or optional I/ O, please contact the Winmate Sales Team for more information.

w/o Box Cover

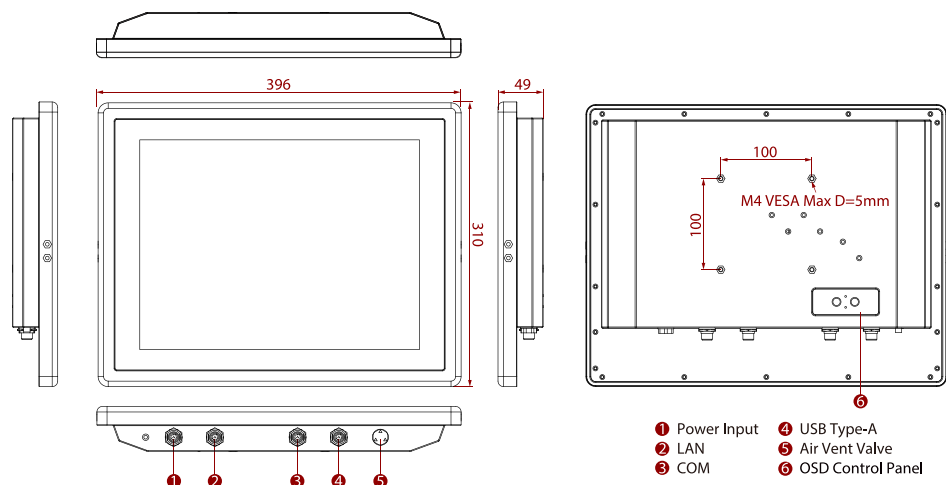

With Box Cover

